

Refrigeration Dryers **SECOTEC®**

Flow rate 0.6 to 14.3 m³/min



SECOTEC®
SECOTEC®

SECOTEC®

SECOTEC refrigeration dryers

SECOTEC refrigeration dryers reliably remove the moisture from compressed air while minimising energy consumption. They feature premium quality components to ensure a long and dependable service life. The cycling control enables significant energy savings. Made in Germany: All SECOTEC refrigeration dryers are built in accordance with the very highest quality standards at KAESER's plant in Gera.

Reliable compressed air drying

As with all KAESER products, SECOTEC dryers are designed and built for maximum reliability. The broad range of available models makes it possible to install the most suitable dryer for virtually any application.

Premium components

High quality, generously-sized components (e.g. in the condenser) ensure optimum flow at all times – even at high operating temperatures – and guarantee a long and dependable service life. Details such as the use of smooth-bore copper piping in the refrigeration circuit also contribute to exceptional system efficiency.

Impressive performance and efficiency

KAESER KOMPRESSOREN's innovative SECOTEC system is a true energy-saver when it comes to compressed air drying: unlike most refrigeration drying systems, KAESER SECOTEC energy-saving dryers consume power only when air actually needs to be dried thanks to their highly efficient cycling control.

Perfect for compressor stations

Every SECOTEC dryer is EN 60204-1 compliant and is tested for electromagnetic compatibility. Unlike equipment conforming to VDE 0700, SECOTEC dryers conform to a strict industrial standard and are equipped with a control cabinet to IP 54, a control transformer and fuses for the control and power circuits. The whole system is designed with maximum safety and reliability in mind.

Reliable refrigerant circuit

The refrigerant circuit in SECOTEC TF refrigeration dryers is specially designed for efficient use of R-134a refrigerant. This ensures maximum efficiency and reliability, even at higher temperatures.

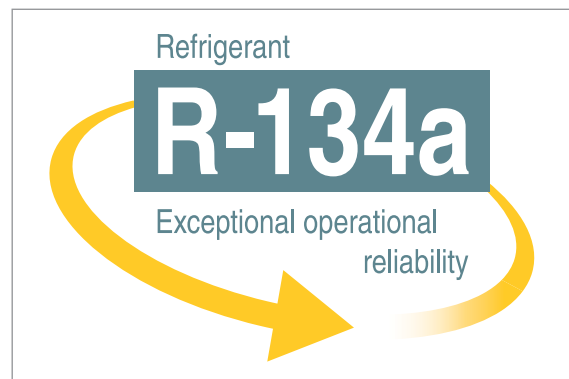

Energy savings all day, every day



Image: SECOTEC TB 19



Image: SECOTEC TE 121

SECOTEC®

Quality counts

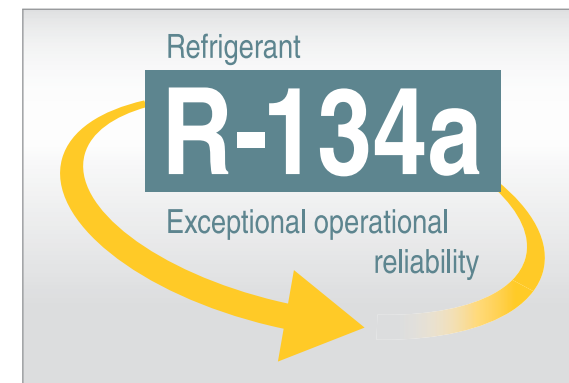

Reliable refrigerant circuit

The refrigerant circuit in SECOTEC TF refrigeration dryers is specially designed for efficient use of R-134a refrigerant. This ensures maximum efficiency and reliability, even at higher temperatures.

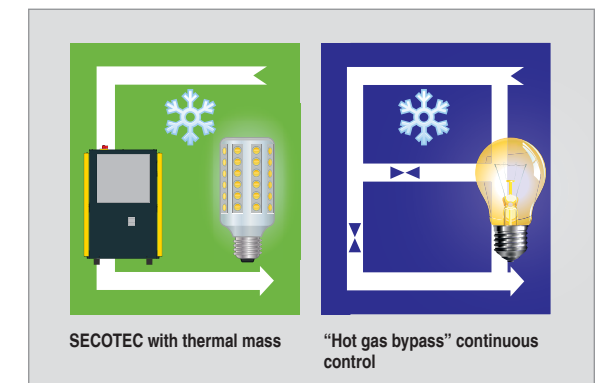

Saves energy: SECOTEC control

The SECOTEC cycling control significantly reduces energy consumption compared with conventional systems with continuous control. The refrigeration circuit is activated only when cooling is actually required.

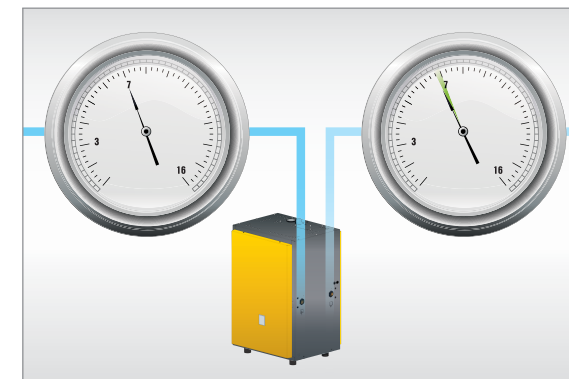

Minimal pressure drop

SECOTEC series dryers ensure minimal pressure drop thereby saving additional energy, as the required maximum pressure is reduced.

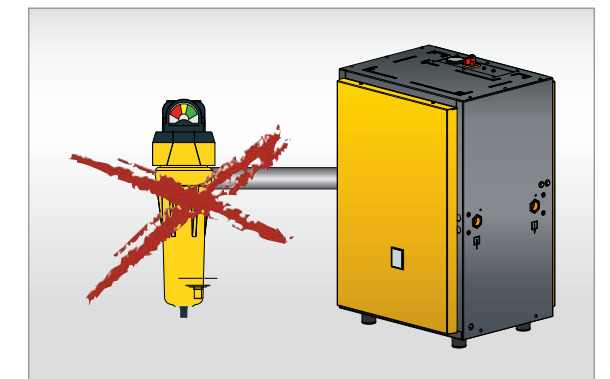

No pre-filter

SECOTEC energy-saving dryers do not require a pre-filter (with piping unaffected by corrosion). This translates into significantly lower investment and maintenance costs, as well as a lower pressure differential.



SECOTEC®

Quality engineered



Efficient condensate separator

KAESER's corrosion-free stainless steel condensate separators provide dependable compressed air drying and ensure reliable condensate separation even at partial load. This is especially important for compressor systems with standby dryers.

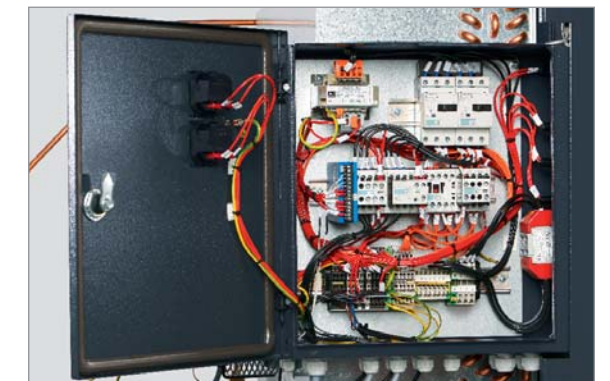

Control cabinet to EN 60204-1

The electrical components in SECOTEC dryers are designed and built in accordance with European standard EN 60204-1 and applicable EMC standards. The dust- and splash-proof IP 54 enclosure ensures maximum safety and durability at all times.



Dependable condensate drainage

Fitted as standard (except for the TA 5 model), the ECO-DRAIN is equipped with an intelligent level-sensing control that prevents pressure loss when the condensate is drained from the air system.

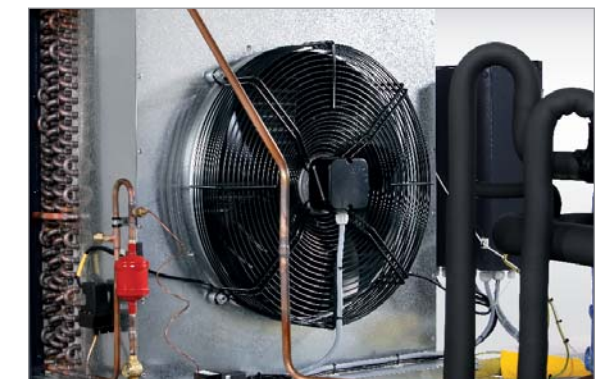

Dependability to +43 °C

Thanks to perfectly matched refrigeration circuit components, SECOTEC dryers provide dependable performance at ambient temperatures of up to +43 °C.

Image:
TE 61 internal view



SECOTEC®

Easy to maintain



Maintenance-friendly design

All components in SECOTEC dryers are easily accessible. Furthermore, the condenser is located at the front of the dryer, which allows possible dirt accumulation to be quickly spotted and rectified.



Excellent accessibility

The SECOTEC refrigeration dryer's enclosure covers are quick and easy to remove. The tower design makes maintenance a breeze, which significantly reduces servicing requirement and therefore costs.



Easy-to-test refrigeration circuit

KAESER service technicians and our partners' technical staff are refrigeration technology experts. They not only check operation of the refrigeration dryer, but also of the cooling circuit itself using intake- and pressure-side service valves.



Dependable condensate drainage

Condensate drains play a key role in ensuring dependable operation of SECOTEC energy-saving dryers. The electronic ECO-DRAIN condensate drains are therefore subject to regular scheduled maintenance and inspection.



The energy-saving effect of the SECOTEC® system

Air consumption over a 24-hour period

Compressed air / Energy consumption

Time

6 - 14

14 - 22

22 - 6

Additional energy-saving potential (for use at summer temperatures, e.g. ambient temperature 40 °C)

Designed for use in ambient temperature

43°C -

40°C -

35°C -

30°C -

25°C -

Energy saving potential

The SECOTEC advantage:

Below the blue line: Air consumption

Above the blue line: Energy-saving potential

Early shift

Day shift

Night shift

Midday break

Air consumption

The TE 91 dryer, for example, can save a total of approximately € 1785 per year with single shift operation compared to dryers which use hot gas bypass control. This cost saving is calculated as follows:

(8760 h - 1000 h) x 1.15 kW x 0.20 €/kWh = € 1785

The graph shows a typical compressed air consumption profile. SECOTEC dryers save energy because the refrigerant system is shut down during breaks, periods of low demand and downtime – the control system operates without fixed run-on periods. The integrated thermal mass ensures that the system is always ready for operation.

Equipment

General design

Tower construction with removable side panels, sheet steel panelling powder-coated outside and galvanised inside; all cold components insulated; all materials CFC-free; the built-in control cabinet is enclosure-protected to IP 54, air to air heat exchanger (model TA 8 upwards); condensate separation system, automatic condensate drain; scope of delivery includes refrigerant and oil.

Operating panel

Equipped with dew point trend gauge, emergency stop switch, LEDs to indicate "Thermal mass active" and "Refrigerant compressor ON".

LEDs for "High dew point" and "ECO-DRAIN alarm" are fitted as standard on TE models and upwards. TF models and upwards feature two operating hours counters.



Refrigerant circuit

Refrigeration circuit features large heat exchanger surface area and service valves, SECOTEC cycling control with thermal mass and automatic dew point control.

Installation example 1

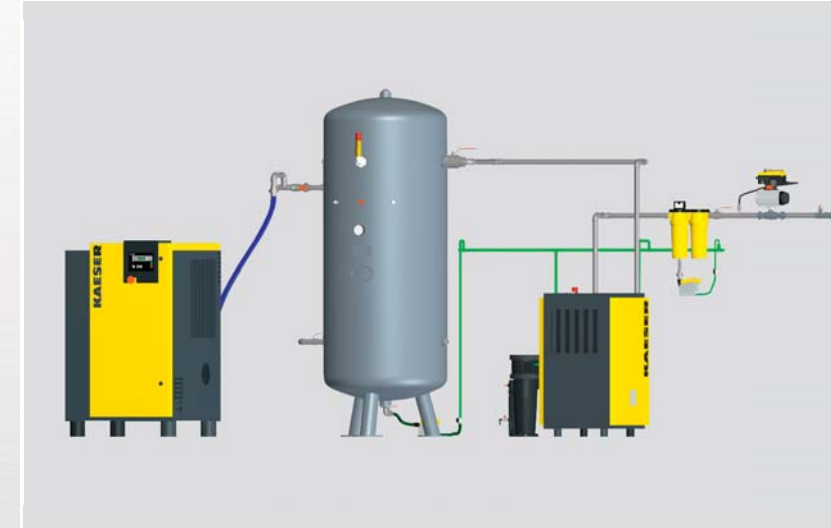

For generally consistent air demand, the SECOTEC refrigeration dryer is located downstream from the air receiver.

Installation example 2

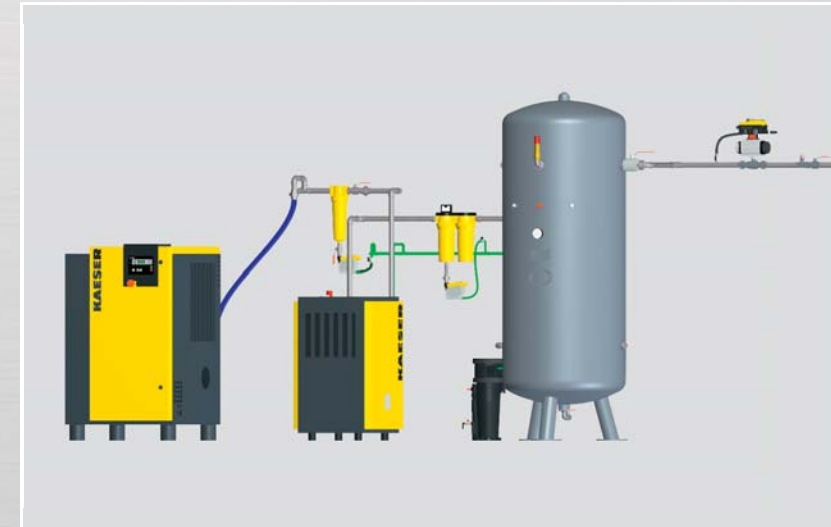

For heavily fluctuating air demand, the SECOTEC dryer is located between the compressor, centrifugal separator with condensate drain and air receiver.

General design

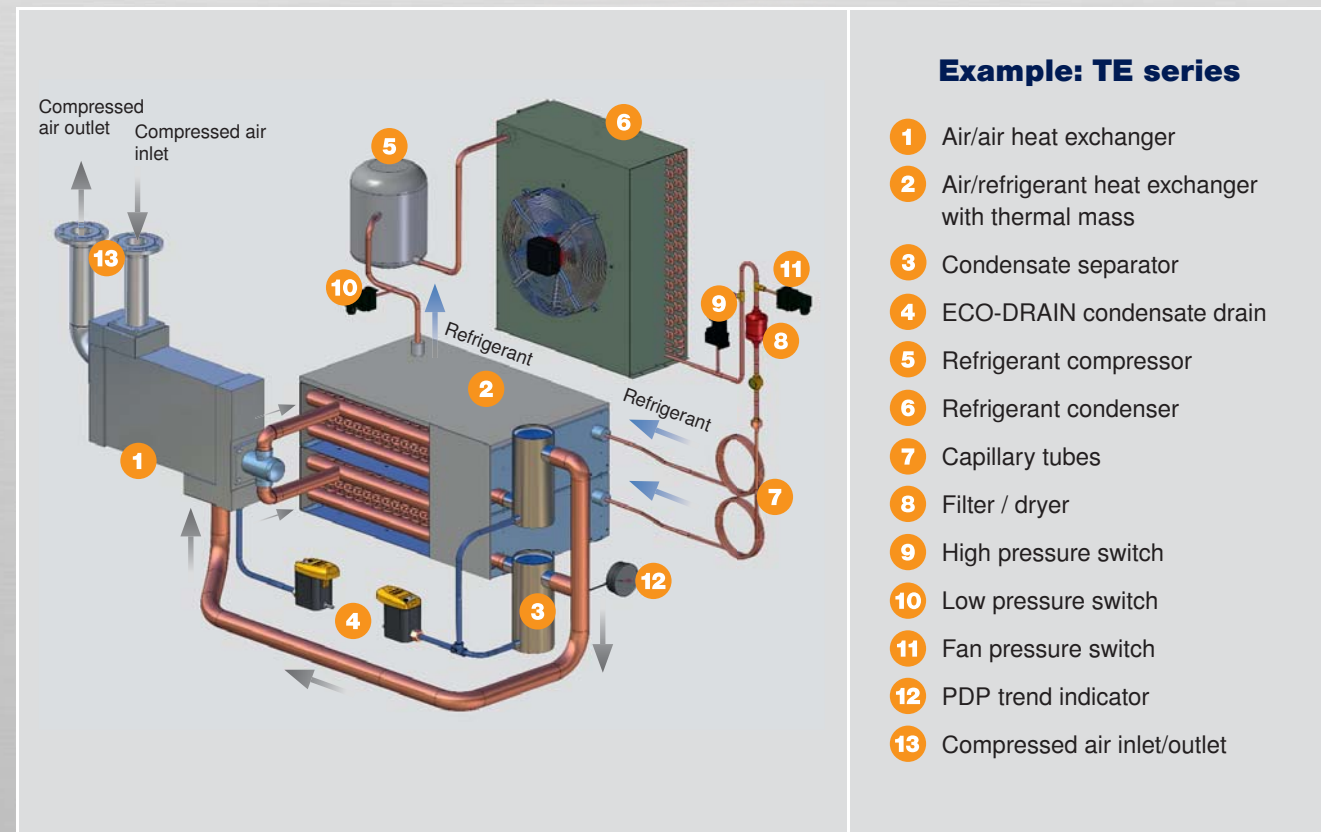

Installation example 3

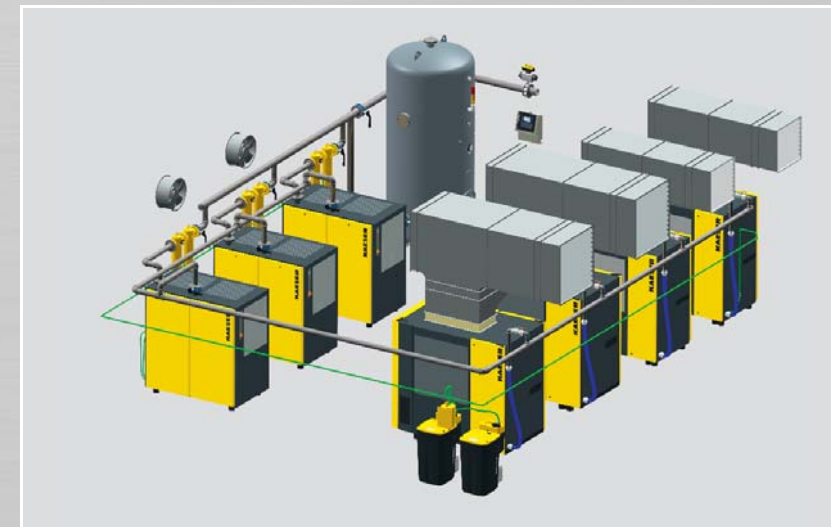

Large compressor systems requiring large volumes of high quality compressed air must have in-built redundancy as part of their design. Sophisticated compressed air supply systems designed and installed from a fully integrated perspective by KAESER's compressed air experts provide long-term durability and efficiency with lowest possible life-cycle costs.

Technical specifications

Model*	Flow rate m³/min	Pressure loss, refrigeration dryer bar	Electrical power consumption at 100 % load kW	Electrical power consumption at 50 % load kW	Mass kg	Dimensions W x D x H Compressed air mm	Connection Compressed air G	Connection Condensate drain G/DN	Electrical connection	Refrigerant mass kg	Refrigerant mass as CO ₂ equivalent t	Hermetic refrigeration circuit as def. F-gases reg.
TA 5	0.60	0.07	0.29	0.16	70	630 x 484 x 779	¾	G ¼	230 V / 1 Ph / 50 Hz	0.27	0.4	•
TA 8	0.85	0.14	0.27	0.15	80					0.22	0.3	•
TA 11	1.25	0.17	0.28	0.15	85					0.36	0.5	•
TB 19	2.10	0.19	0.55	0.30	108	620 x 540 x 963	1	DN 10 ¼	230 V / 1 Ph / 50 Hz	0.60	0.9	•
TB 26	2.55	0.20	0.62	0.34	116					0.58	0.8	•
TC 31	3.20	0.15	0.75	0.41	155	764 x 660 x 1009	1 ¼	DN 10 ¼	230 V / 1 Ph / 50 Hz	0.76	1.1	•
TC 36	3.90	0.16	0.88	0.48	170					0.97	1.4	•
TC 44	4.70	0.15	0.89	0.49	200					1.13	1.6	•
TD 51	5.65	0.11	0.86	0.47	251	1125 x 759 x 1187	1 ½	DN 10 ¼	400 V / 3 Ph / 50 Hz	1.25	1.8	•
TD 61	7.00	0.15	1.10	0.61	251					1.28	1.8	•
TD 76	8.25	0.17	1.40	0.77	287		2			1.50	2.1	•
TE 91	10.15	0.15	1.15	0.63	570	1520 x 1060 x 1513	2	2xDN 10 ¼	400 V / 3 Ph / 50 Hz	1.90	2.7	•
TE 121	12.70	0.18	1.45	0.80	660					2.10	3.0	•
TE 141	14.30	0.24	1.60	0.88	660					2.10	3.0	•

*) Suitable for ambient temperatures from +3 to +43 °C. Max. compressed air intake temperature +55 °C; Gauge pressure min./max. 3 to 16 bar
Performance characteristics at reference conditions to ISO 7183 Option A1: Operating pressure 7 bar, ambient temperature +25 °C, compressed air inlet temperature +35 °C, pressure dew point +3 °C. The flow rate changes for deviating operating conditions. Contains fluorinated greenhouse gas R-134a (GWP = 1,430).

Correction factors for deviating operating conditions (flow rates in m³/min x k...)

Deviating working pressure p at dryer inlet

Model	p bar (g)	3	4	5	6	7	8	9	10	11	12	13	14	15	16
TA-TE	k _p	0.75	0.84	0.90	0.95	1.00	1.04	1.07	1.10	1.12	1.15	1.17	1.19	1.21	1.23

Compressed air inlet temperature T_i

Model	T _i (°C)	30	35	40	45	50	55
TA-TE	k _{Ti}	1.20	1.00	0.83	0.72	0.60	0.49

Ambient temperature T_a

Model	T _a (°C)	25	30	35	40	43
TA-TE	k _{Ta}	1.00	0.99	0.97	0.94	0.92

Calculation of flow rate under deviating operating conditions:

Example:

Working pressure: 10 bar (g) > Table > k_p = 1.10
Compressed air inlet temperature: 40 °C > Table > k_{Ti} = 0.83
Ambient temperature: 30 °C > Table > k_{Ta} = 0.99

Selected refrigeration dryer: TB 19 with 2.1 m³/min (V_{Reference})

$$V_{\text{max. operation}} = V_{\text{Reference}} \times k_p \times k_{T_i} \times k_{T_a}$$

$$V_{\text{max. operation}} = 2.1 \text{ m}^3/\text{min} \times 1.1 \times 0.83 \times 0.99 = 1.9 \text{ m}^3/\text{min}$$

Dimensions

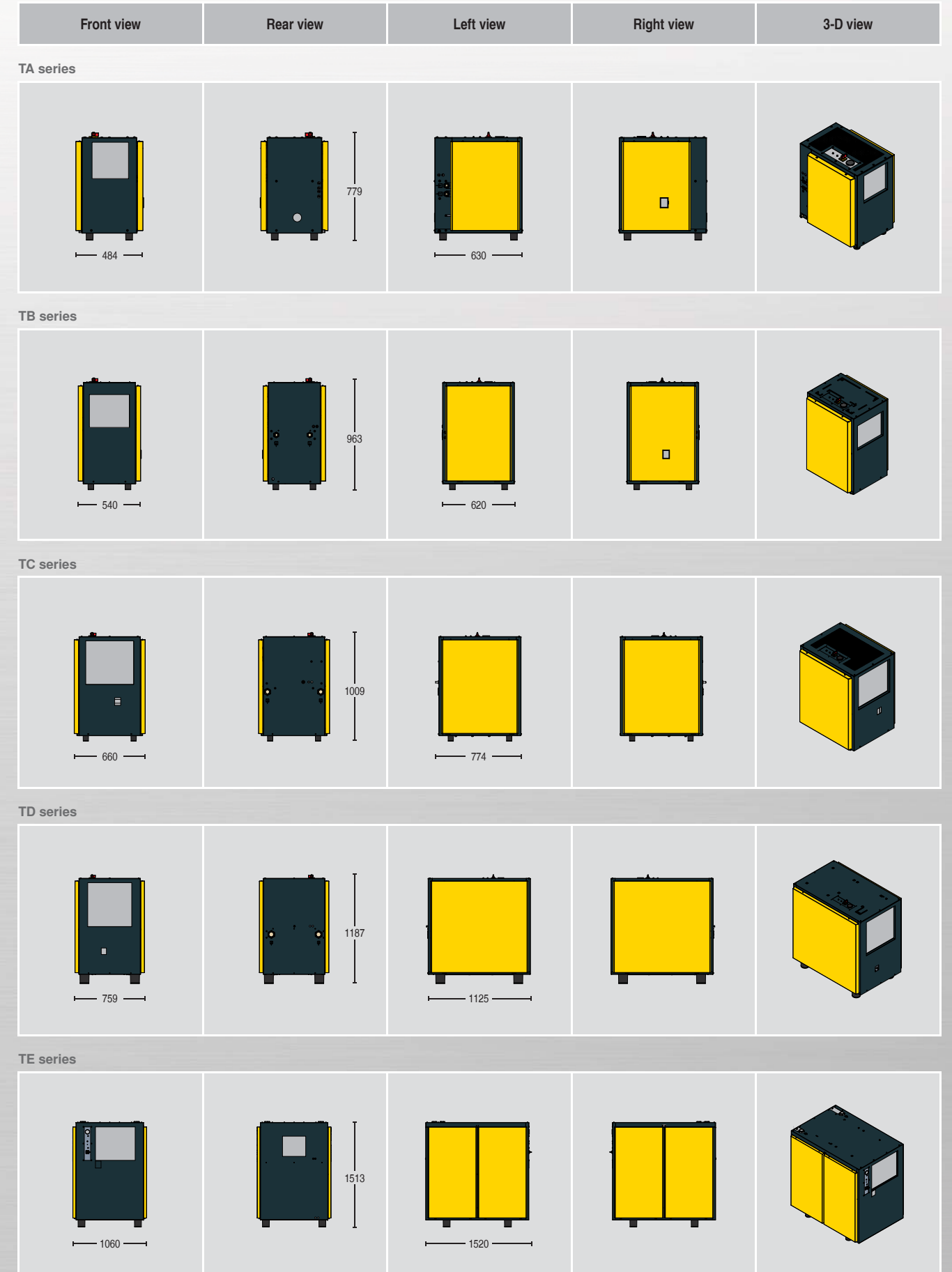

Choose the required grade of treatment according to your field of application:

Application examples: Selection of treatment classes to ISO 8573-1 (2010)

Air treatment with refrigeration dryer

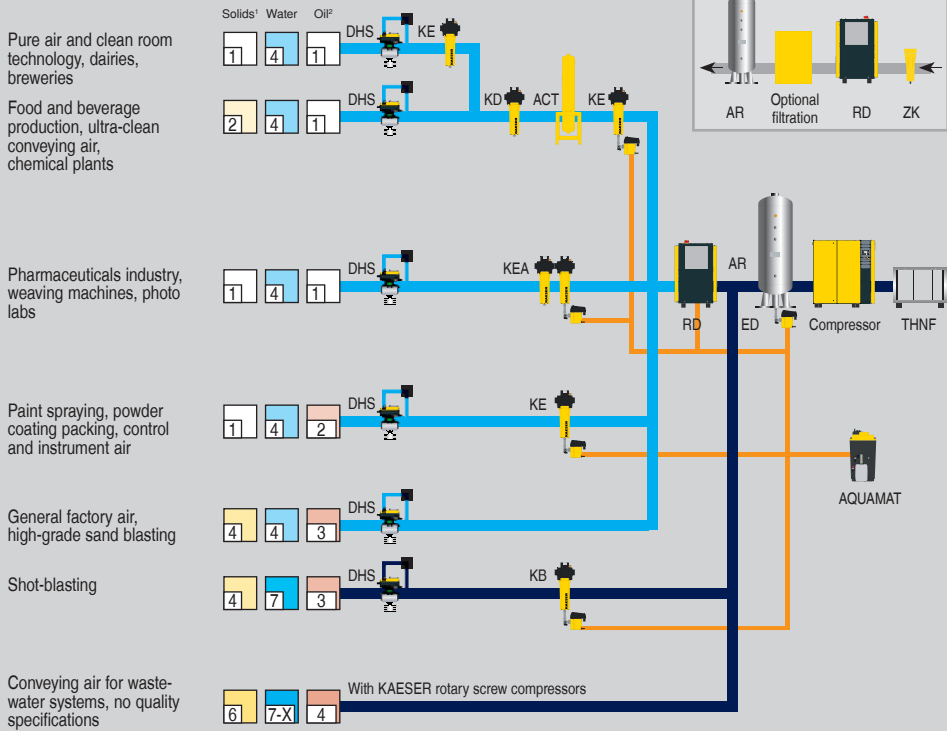

Compressed air treatment with desiccant dryer

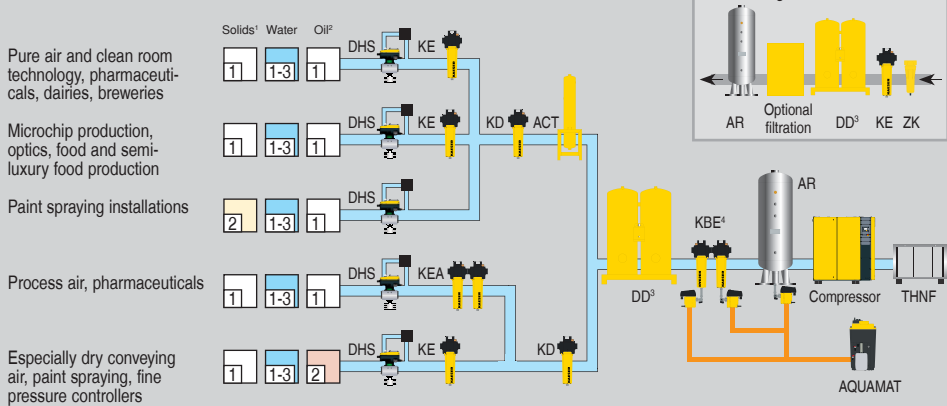

1) Achievable particle class at proper pipe system and commissioning.
 2) Achievable total oil content when using recommended compressor oils and clean inlet air.
 3) Downstream of heat-regenerated desiccant dryers, high-temperature filters are required, and an aftercooler if required.
 4) In critical applications requiring high compressed air purities (e.g., electronics and optics), we recommend the use of an Extra combination (filter combination of KB and downstream KE filter).

	Explanation
ACT	Activated carbon adsorber
AQUAMAT	AQUAMAT
DD	Desiccant dryer
DHS	Air-main charging system
AR	Air receiver
ECD	ECO-DRAIN
KA	Activated carbon filter, adsorption
KB	Coalescence filter, Basic
KBE	Extra combination
KD	Particulate filter, dust
KE	Coalescence filter, Extra
KEA	Carbon combination
RD	Refrigeration dryer
THNF	Bag filter
ZK	Centrifugal separator

Compressed air quality classes to ISO 8573-1(2010):

Solid particles/dust			
Class	Max. particle count per m³ * of a particle size d in [µm]		
	0.1 ≤ d ≤ 0.5	0.5 ≤ d ≤ 1.0	1.0 ≤ d ≤ 5.0
0	Please consult KAESER regarding specific requirements		
1	> 20,000	≤ 400	≤ 10
2	≤ 400,000	≤ 6,000	≤ 100
3	Not defined	≤ 90,000	≤ 1,000
4	Not defined	Not defined	≤ 10,000
5	Not defined	Not defined	≤ 100,000
Particle concentration C _p in mg/m³ *			
6	0 < C _p ≤ 5		
7	5 < C _p ≤ 10		
X	C _p > 10		

Water	
Class	Pressure dew point, in °C
0	Please consult KAESER regarding specific requirements
1	≤ -70 °C
2	≤ -40 °C
3	≤ -20 °C
4	≤ +3 °C
5	≤ +7 °C
6	≤ +10 °C
Concentration of liquid water C _w in g/m³ *	
7	C _w ≤ 0.5
8	0.5 < C _w ≤ 5
9	5 < C _w ≤ 10
X	C _w > 10

Oil	
Class	Total oil concentration (fluid, aerosol + gaseous) mg/m³ *
0	Please consult KAESER regarding specific requirements
1	≤ 0.01
2	≤ 0.1
3	≤ 1.0
4	≤ 5.0
X	> 5.0

* At reference conditions 20 °C, 1 bar(a), 0% humidity

